

Drum Crusher/In-Drum Compactor

Reduce Disposal Costs

- **60,000 lbs. compaction force** reduces drums to 4" pancakes
- **Rugged**, fully enclosed compaction chamber
- **Automatic** push button controls
- **Safety interlock** prevents operation if door is open
- **Second compaction head** quickly converts drum crusher to in-drum compactor
- **Location plate** keeps drums centered in chamber
- **Forklift pockets** allow for easy removal of heavy compacted drums
- **Large feed area** accepts even 5-gallon pails for in-drum compacting
- **Options** include xp motor, drip pan, remote operator station and platen spike



EIGHT DRUMS CRUSH TO A HEIGHT OF 4"
EACH TO OCCUPY THE SPACE OF ONE
DRUM



**Totally Explosion Proof
Drum Crusher For Use In
Class 1, Div 1 Hazardous
Areas**

VIP
VANGUARD
Industrial Products

81 Edgewood Drive, Avon Lake, OH 44012
Toll Free (866) 511-3746 Fax (216) 803-1189
Www.vanguardindustrial.com
Email: info@vanguardindustrial.com

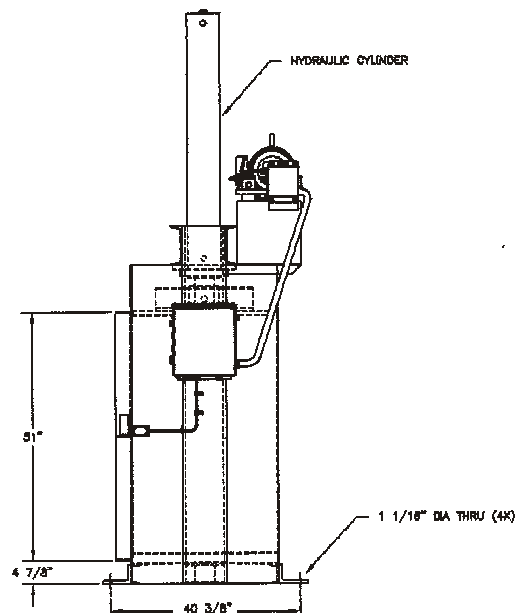
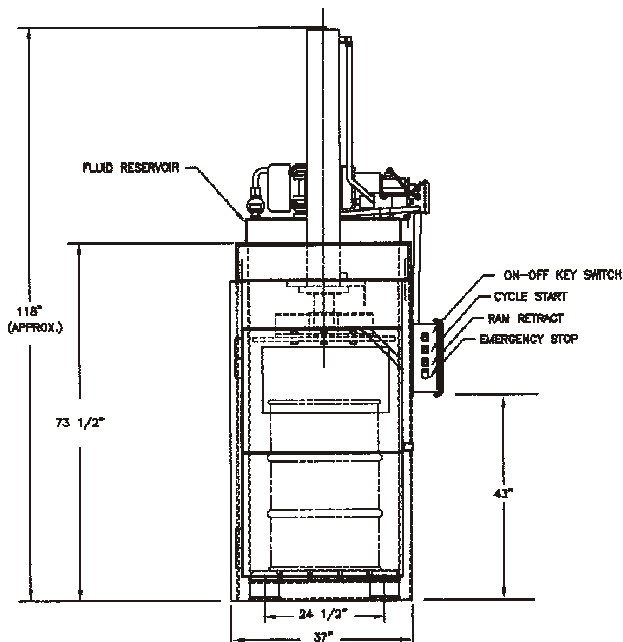
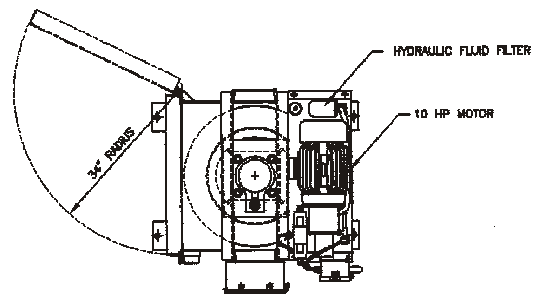
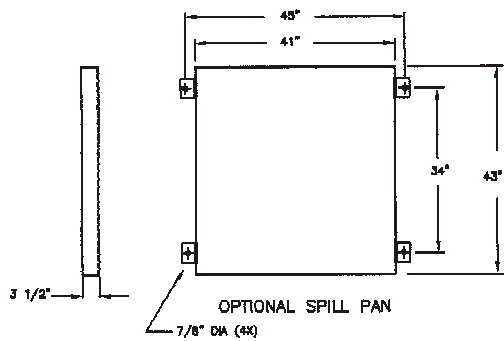

SPECIFICATIONS

OVERALL HEIGHT	117 12"
OVERALL WIDTH	43"
OVERALL DEPTH	38"
CRUSHING/PACKING CHAMBER HEIGHT	48"
CYLINDER rod	6" bore x 45" stroke x 4"
MOTOR	10 h.p. 3/60/208-240-480
COMPACTING FORCE	60,759 lbs.
SYSTEM PRESSURE	2,150 psi
SHIPPING WEIGHT	2,500 lbs.

OPTIONS

- Explosion Proof Motors and Single Phase Motors
- Remote Operator Station
- Drip Pan
- Platen Spike